

Handantrieb
Manual drive
Entraînement manuel
Accionamiento manual

Antriebsart Type of motor Mode d'entraînement Tipo de accionamiento	Art.-Nr.		VE	max. Hubkraft Max. lifting capacity Puissance de levage max. Fuerza máxima de desplazamiento	max. Hubhöhe Max. lifting height Hauteur de levage max. Altura máxima de desplazamiento	max. Last Max. load Charges max. Carga máx.	b min. b min. b min. b mín.	h min. h min. h min. h mín.	
Einzelantrieb Single drive Commande individuelle Accionamiento individual	248740 248741	RAL 9016 RAL 9006	Stück Quantity 1 Pièce Unidad	250 N	220 mm	*	600 mm	750 mm	266254

Handantriebe sind durch Schliessen des Dachfensters vor erhöhter Windkraft zu schützen.
Close the roof window to protect the manual actuators against increased wind load.

Les manœuvres manuelles doivent être protégées contre la force du vent en fermant l'ouvrant en toiture.

Los accionamientos manuales deben protegerse del aumento de la fuerza del viento cerrando la ventana de cubierta.

* Werte gelten für Dachneigung = 7°
Values apply for roof pitch = 7°
Valeurs valables pour inclinaison de toiture = 7°
Los valores sirven para una inclinación de cubierta = 7°

max. Flügelgewicht = 1200 N
Max. vent weight = 1200 N
Poids d'ouvrant max. = 1200 N
Máximo peso de hoja = 1200 N

Elementmitte / Einzelantrieb
Centre of unit / single actuator
Milieu de l'élément / entraînement individuel
Centro del elemento / Accionamiento individual

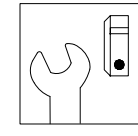
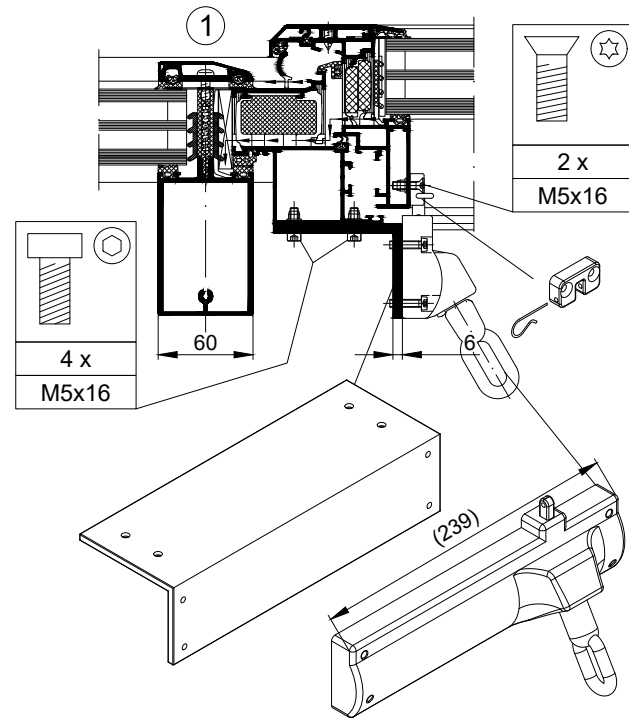
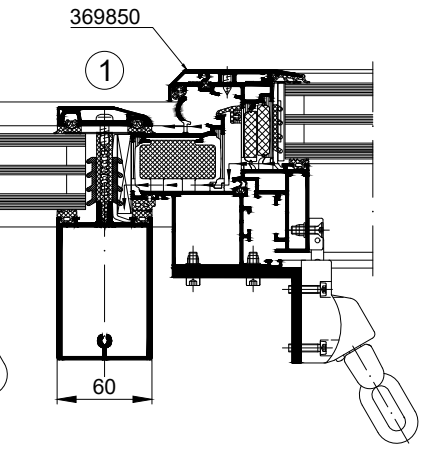
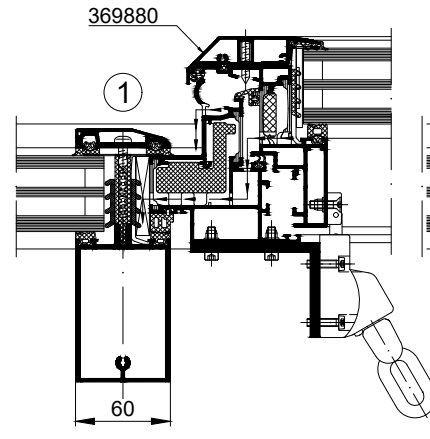
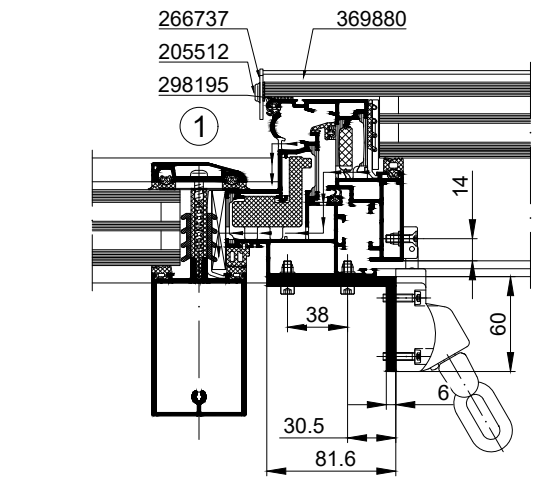
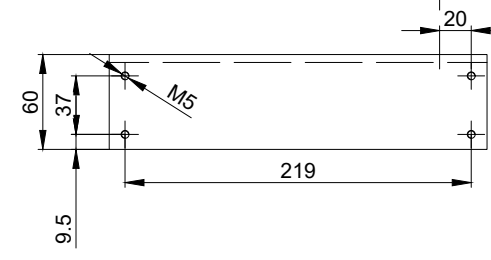
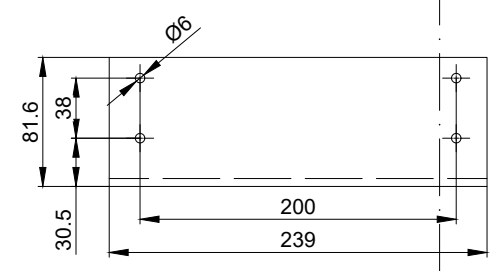
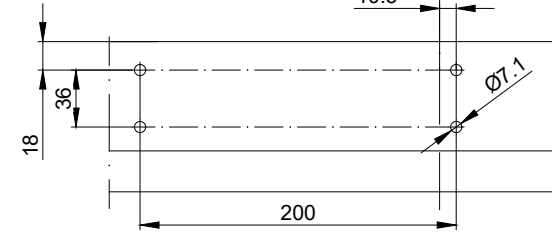
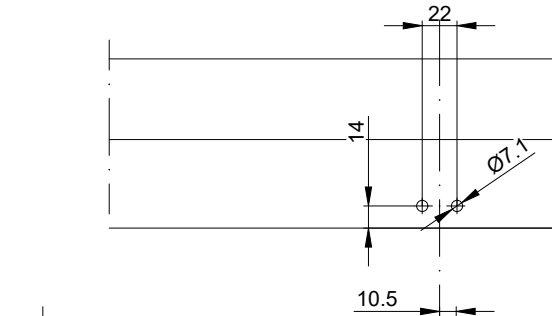
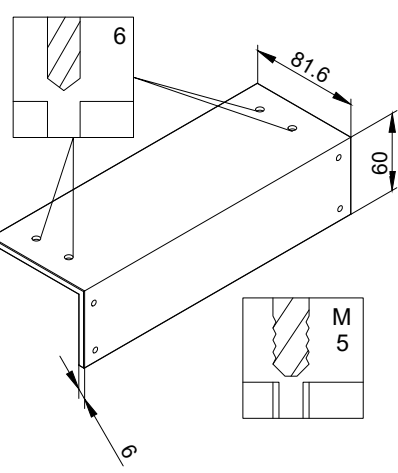
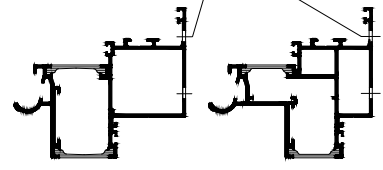
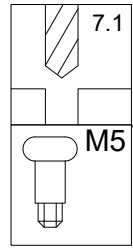
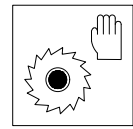

Mindestabmaße der Elemente abhängig vom Öffnungsantrieb
Minimum dimensions for the units will depend on the type of opener
Les dimensions minimales des éléments dépendent du moteur d'ouverture
Dimensiones mínimas del elemento en función del accionamiento de apertura

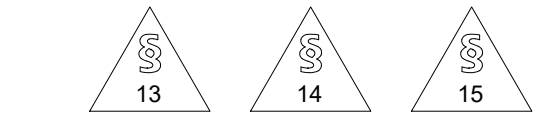

Profilbearbeitung - Handbetätigung Profile preparation - Manual operation Usinage des profilés - Commande manuelle Mecanizado de perfiles - Accionamiento manual	K1027821 0201 Schüco AW RO 50
---	--